



IS WOODWORKERS A MOULDING COMPANY?

No. Woodworkers is a joinery company that supplies and stocks mouldings in specialist profiles or timbers not available from timber retailers or merchants. Our moulding capability is more at the boutique rather than the supermarket end of the scale. We do carry a limited range of profiles in stock to accompany our restoration and door products but most larger orders are custom run. We specialise in red cedar mouldings that match and compliment our joinery range.

WHAT SIZE LIMITATIONS APPLY?

Natural timber rarely comes in lengths longer than 2.7 – 3.0 metres as merchants usually fit two blocks of timber end to end into a 20 foot (6m) container thereby restricting the sizes available. This is very different to finger joint pine moulds which come in 5.4 metre lengths (because they are an engineered product) but can only be used for painted applications. Widths in natural timber are rarely wider than 200mm due to fears of cupping and bowing of wider planks, so where very wide Victorian style mouldings are required it is usually necessary to make them in 2 or more parts. All mouldings are priced according to the rough sawn size from which they are extracted, usually either 25mm, 38mm or 50mm thick.

WHAT MOULDINGS DO YOU CARRY IN STOCK?

All of the profiles shaded in grey are stock profiles in red cedar generally held in our Moorooka factory. Common profiles such as AAY architraves are also generally available in paint grade timber. Our retail centres may also carry overruns or seconds at discounted prices.

WHY USE RED CEDAR MOULDINGS?

In both traditional and contemporary work, it greatly enhances the presentation of doors if the framing and dressing timbers match the doors. Profiles are available in sizes 90x19 or 68x19 for general architrave work, or run to size for other applications. Red cedar can be a difficult timber to run mouldings in and may fur up at cross grain points. Woodworkers prides itself that many of our heritage mouldings are accurately matched from originals and therefore tend to be more voluptuous and curvaceous than the sterile offerings of most moulding companies. The flowing curves of our moulds sometimes result in furring at intervals in moulding which are easily removed once a surface coating is applied (see separate FAQ sheet 1 on finishing).

HOW DO I DESCRIBE THE SHAPES I AM LOOKING FOR?

The traditional names for the classic shapes below have been in use for centuries

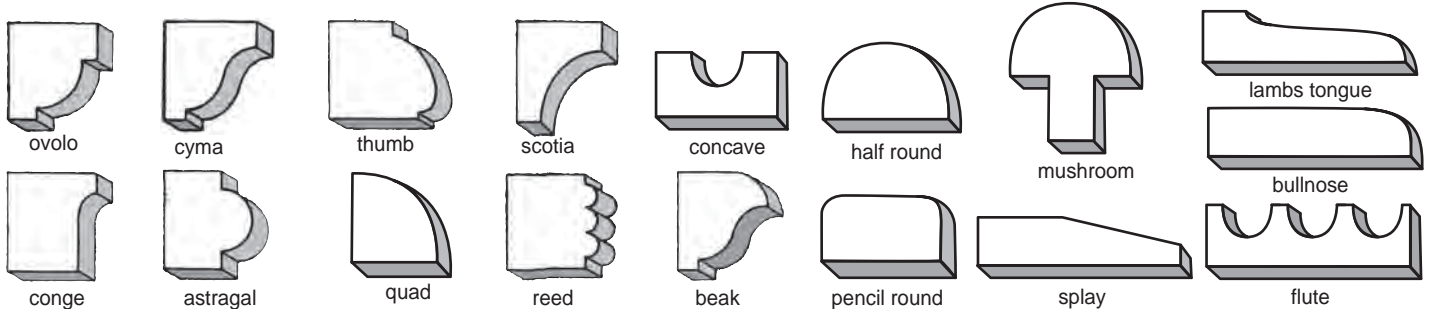

cedar joinery deserves cedar mouldings to enhance its impact

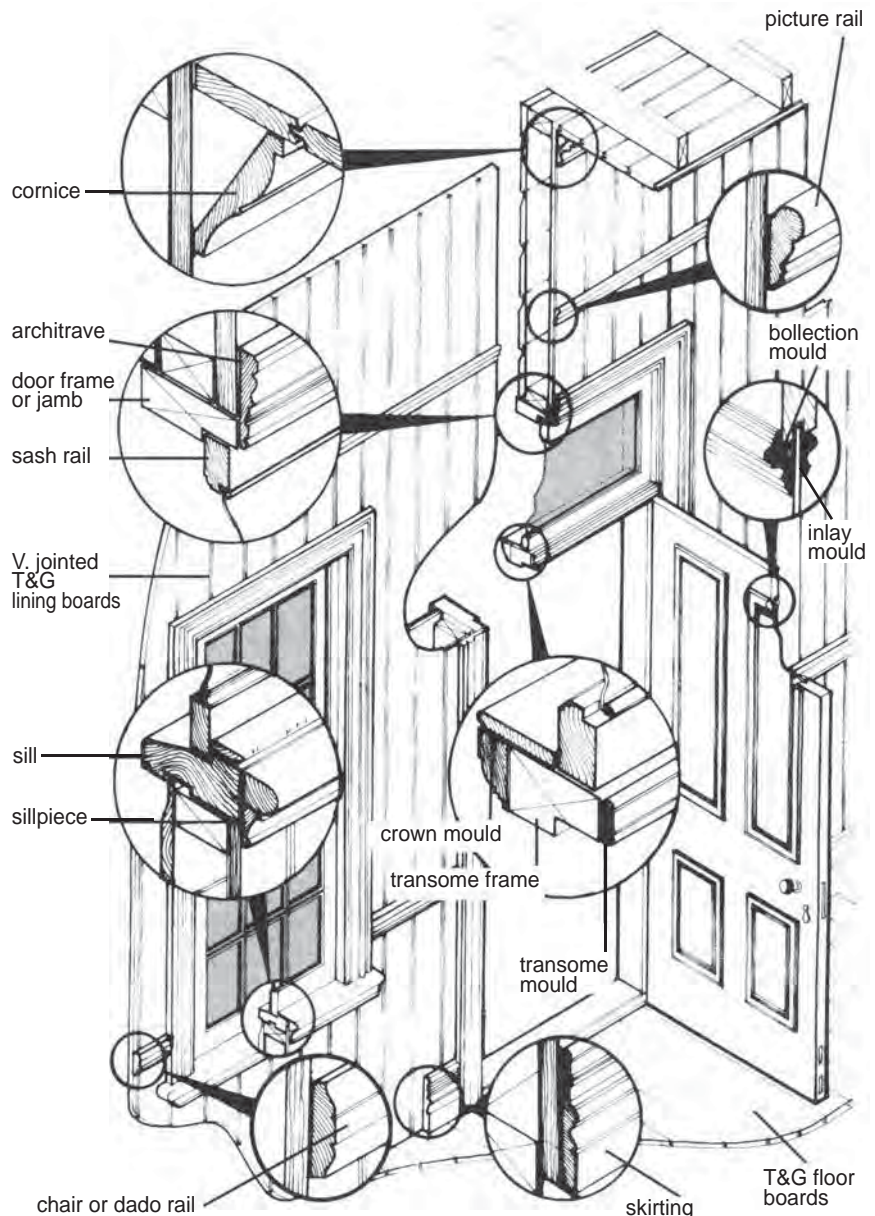

BRISBANE
1095 Ipswich Rd
Moorooka 4105
☎ 07 3848 1383
F: 07 3892 1476

GOLD COAST
Warehouse Road
Southport 4215
☎ 07 5571 0088
F: 07 5571 0617

SUNCOAST
53 Wisers Road
Maroochydore
☎ 07 5479 0999
F: 07 5479 0911

SYDNEY
2 Sydenham Rd
Brookvale 2100
☎ 02 9938 4999
F: 02 9938 4666

ARCHITRAVE & SKIRTINGS

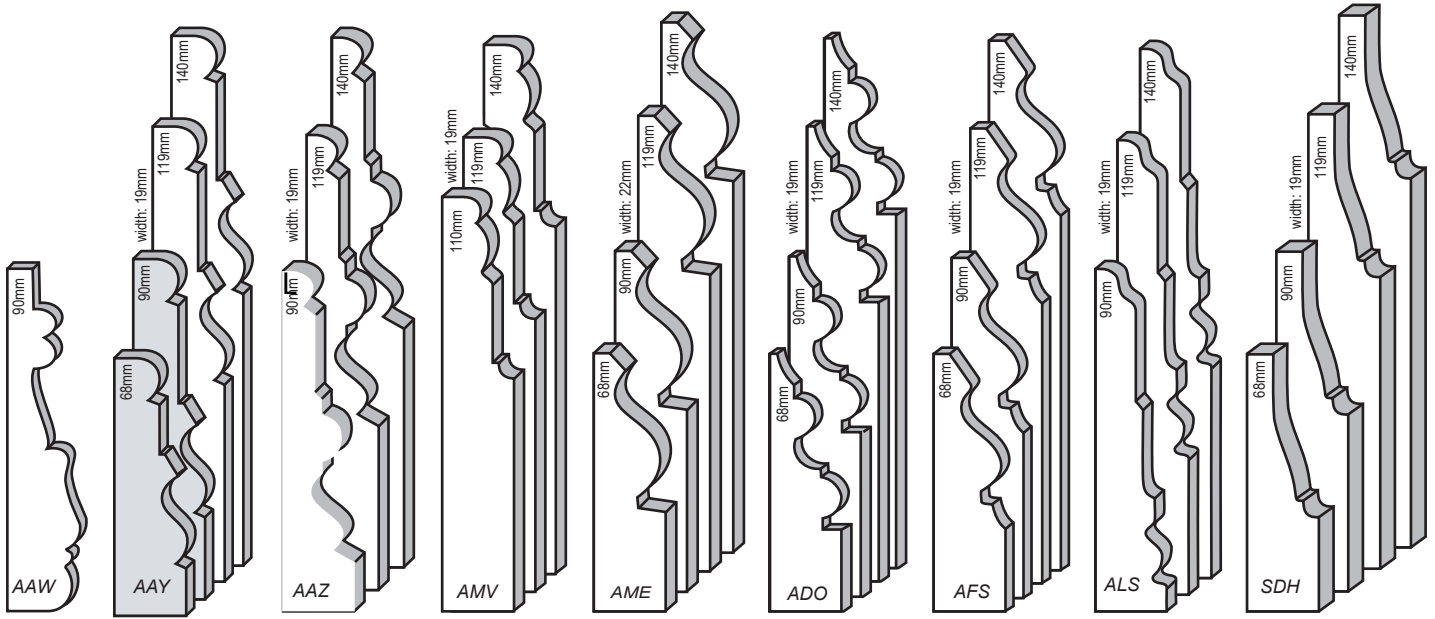

shown at half full size

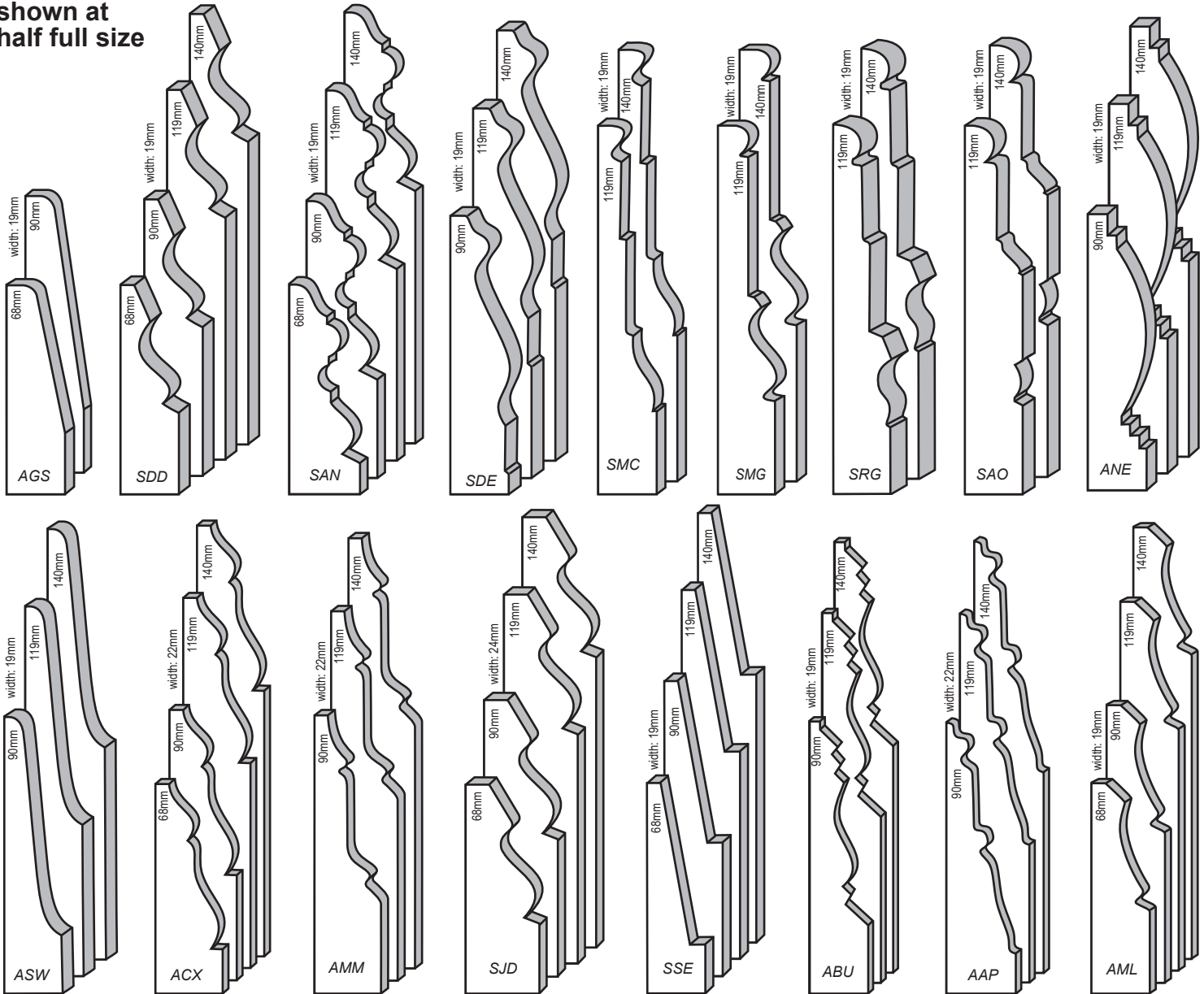

BRISBANE
1095 Ipswich Rd
Mooroooka 4105
☎ 07 3848 1383
F: 07 3892 1476

GOLD COAST
Warehouse Road
Southport 4215
☎ 07 5571 0088
F: 07 5571 0617

SUNCOAST
53 Wises Road
Maroochydore
☎ 07 5479 0999
F: 07 5479 0911

SYDNEY
2 Sydenham Rd
Brookvale 2100
☎ 02 9938 4999
F: 02 9938 4666

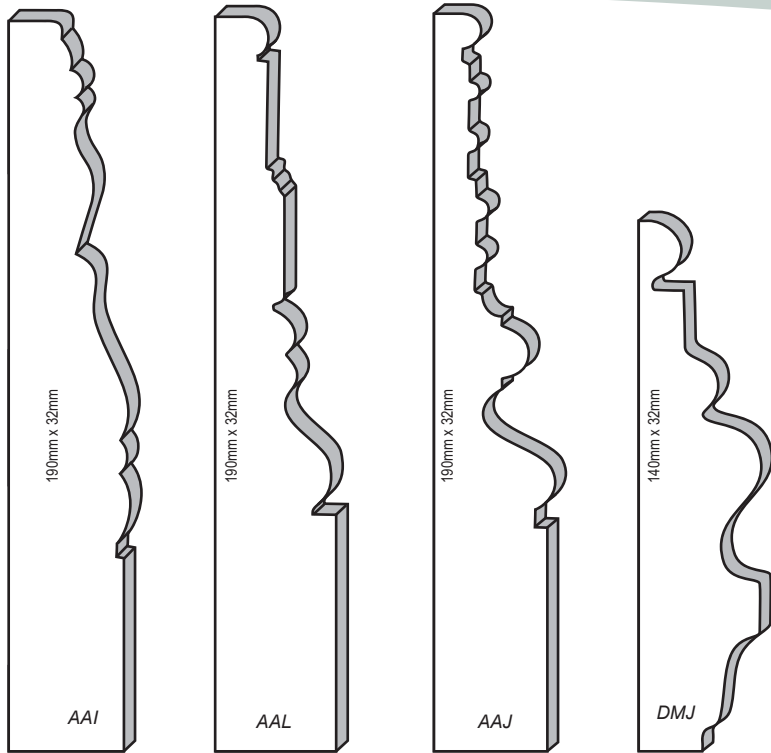

PRICES WHERE SHOWN ARE IN SURIAN RED CEDAR

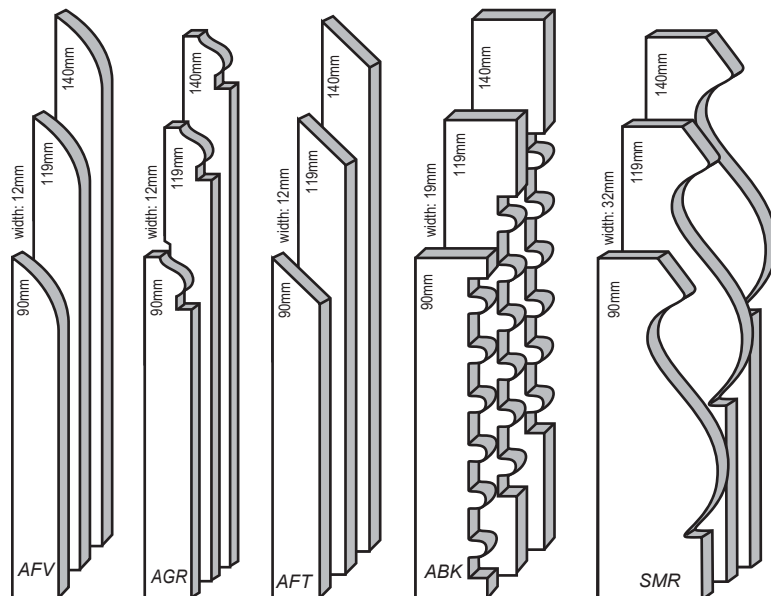
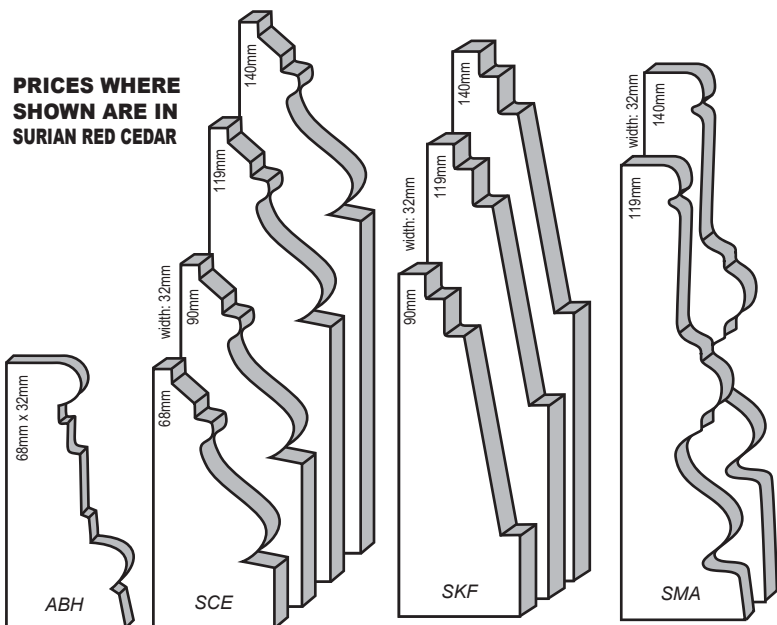

CORNICE MOULDS

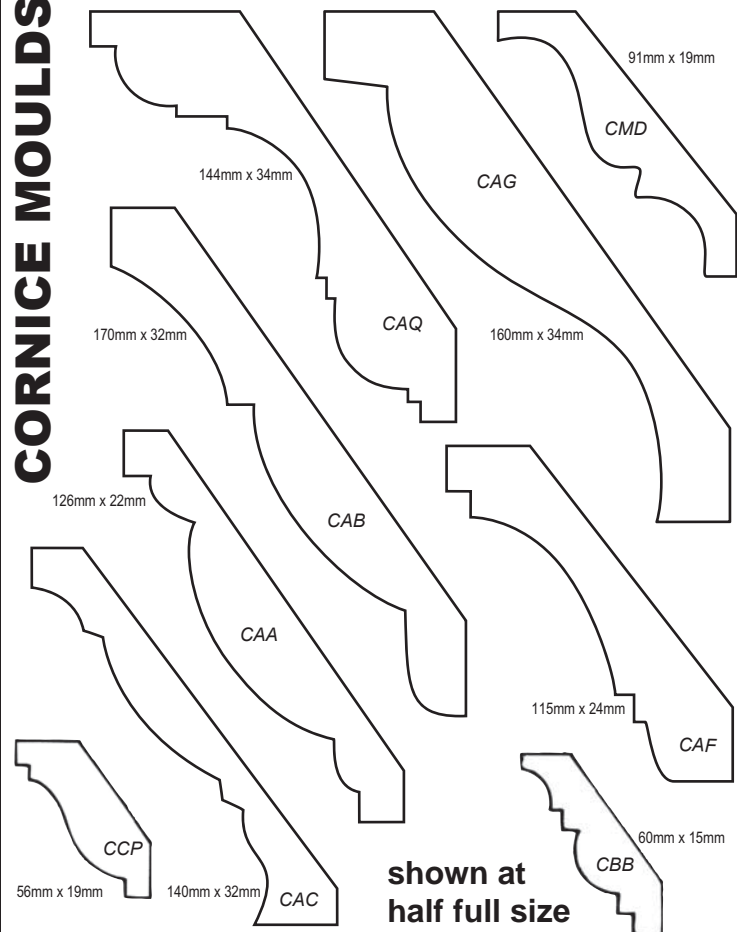

shown at half full size

BOLLECTIONS MOULDS

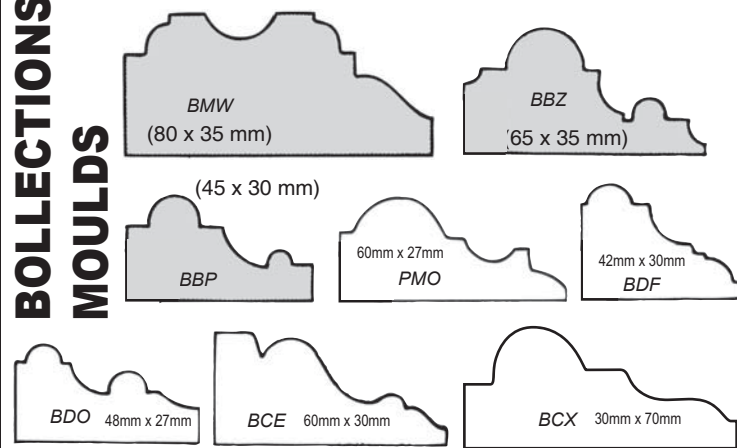

STOP BEADS

STOP BEAD PRICES

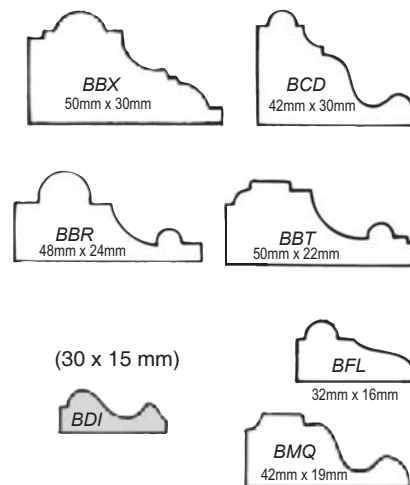
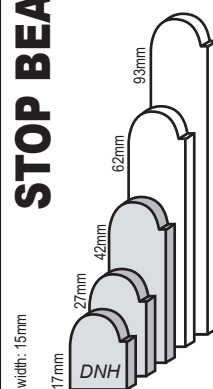

BRISBANE
1095 Ipswich Rd
Moorooka 4105
☎ 07 3848 1383
✉ 07 3892 1476

GOLD COAST
Warehouse Road
Southport 4215
☎ 07 5571 0088
✉ 07 5571 0617

SUNCOAST
53 Wisers Road
Maroochydore
☎ 07 5479 0999
✉ 07 5479 0911

SYDNEY
2 Sydenham Rd
Brookvale 2100
☎ 02 9938 4999
✉ 02 9938 4666

19 TURNERY, SILLS & DRESSED TIMBER

IMPORTANT NOTE

Some items may vary slightly from the sketches shown on this page.

STOCK SILLS

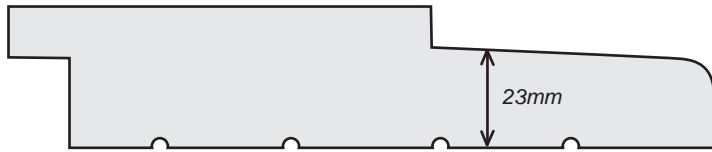

outward opening french door sill

Merbau or Kwila

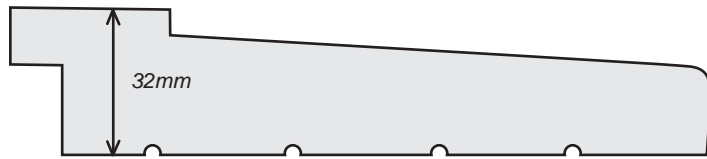

inward opening french door sill

Merbau or Kwila



large inward opening french door sill

Merbau or Kwila

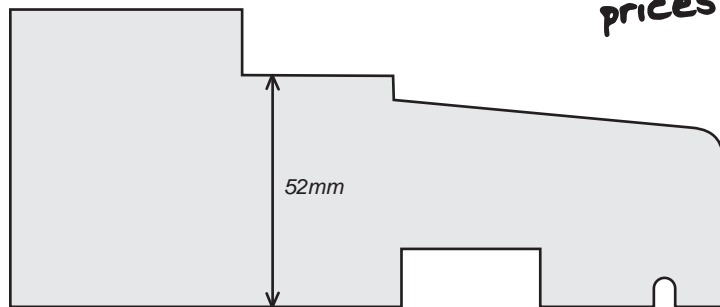

casement sill

Merbau or Kwila

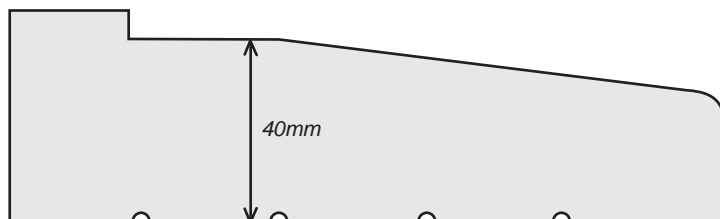

double hung sill

Merbau or Kwila

KWILA POST CAPITOLS, CROWNS (ex 100 x 100 mm)

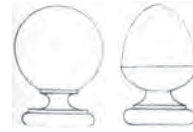

Ball-A

Acorn-B

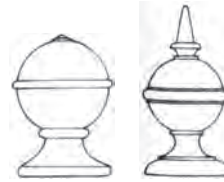

Crown 2

Crown 3



70 x 70 ROOF FINIALS

TURNING SIZES

Finials (70 x 70)

650 mm long •
760 mm long §
950 mm long †

Flat sections:

"•" is 270 mm,
"§" is 300 mm
"†" is 340 mm

DRESSED ALL ROUND RED CEDAR MOULDINGS

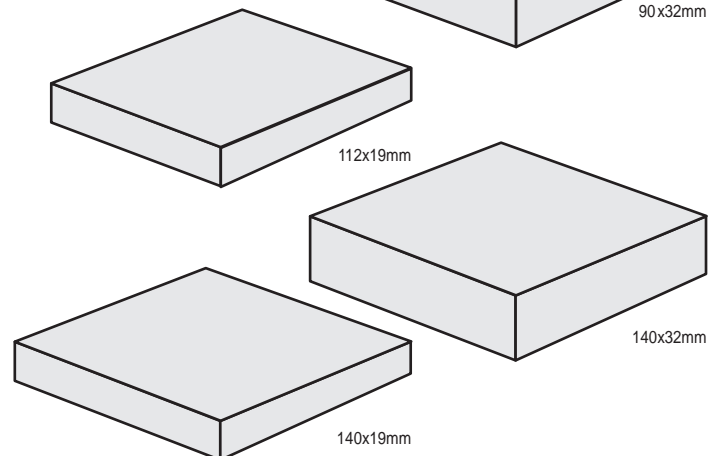
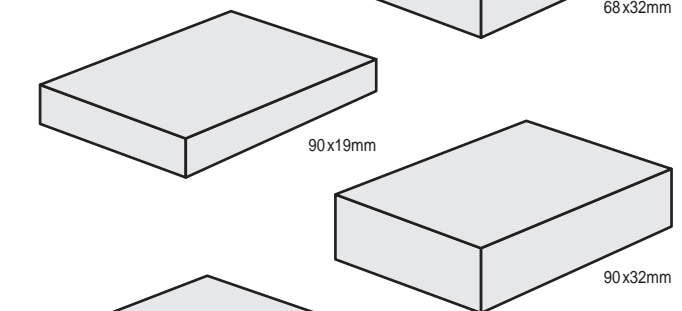
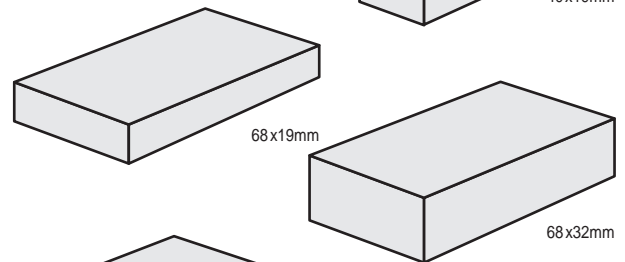
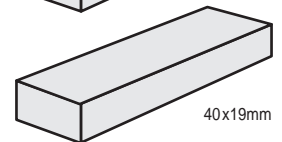
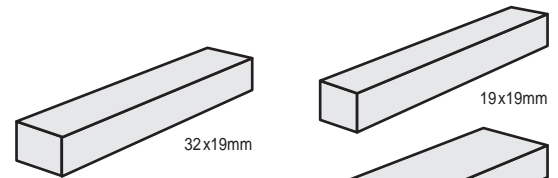

*compare our
prices!*

BRISBANE
1095 Ipswich Rd
Moorooka 4105
☎ 07 3848 1383
F: 07 3892 1476

GOLD COAST
Warehouse Road
Southport 4215
☎ 07 5571 0088
F: 07 5571 0617

SUNCOAST
53 Wisers Road
Maroochydore
☎ 07 5479 0999
F: 07 5479 0911

SYDNEY
2 Sydenham Rd
Brookvale 2100
☎ 02 9938 4999
F: 02 9938 4666

HOW DO I MATCH EXISTING MOULDINGS?

Where you have gaps in your existing mouldings it is often more economical to cannibalise from elsewhere in the house to reinstate complete rooms and to purchase new material for secondary areas. If it is essential that you accurately match existing mouldings you will need to provide a cutting or a template of the original mouldings so that we can ascertain if blades are available to cut the profile in one or more passes through our spindle moulders. Woodworkers carry a range of hundreds of different shapes accumulated over decades of restoration work and you may be lucky that we have the blades you need. Sometimes a single moulding run is all you need but more commonly, a combination of blades and profile runs is required to carve out the shape you need. You can expect to pay a set up charge of approx \$110 per machine set up for each part of a moulding, plus the cost of the timber and labour used in the finished product. Where we do not have cutters able to duplicate a profile it may be necessary for you to pay to have blades made to precisely match your mouldings. Blade cutting is a time consuming and expensive affair using high speed steel pairs of blades which are retained by woodworkers at the completion of the run. You can expect to pay costs of \$300 plus profiling changes plus set up time, material and labour costs. If you need a substantial quantity of mouldings this upfront cost per metre will not be excessive but for small quantities it may prove prohibitive.

DO YOU RUN MOULDINGS IN MY OWN TIMBER?

Woodworkers will run profiles in timber supplied by clients provided the timber is completely free of any nails or other problems. The work is done at your risk and, should replacement blades be necessary, at your expense.

HOW ARE MOULDINGS INSTALLED?

Most mouldings are simply mitre cut at junctions where they are in the same plane e.g. architraves, but more elaborate methods are required for junctions between two opposite planes. A scribed joint is used where shaped mouldings meet at an interior angle. They are made by square cutting one moulding to butt into the junction and then undercutting the second moulding to the profile of the first. Mitred joints are used to join mouldings at exterior angles. The most common architectural detail to resolve with mouldings is the architrave and skirting junctions, which are usually either butt, mitre or block joined using rosettes & plinths.

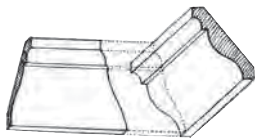

scribed cornice

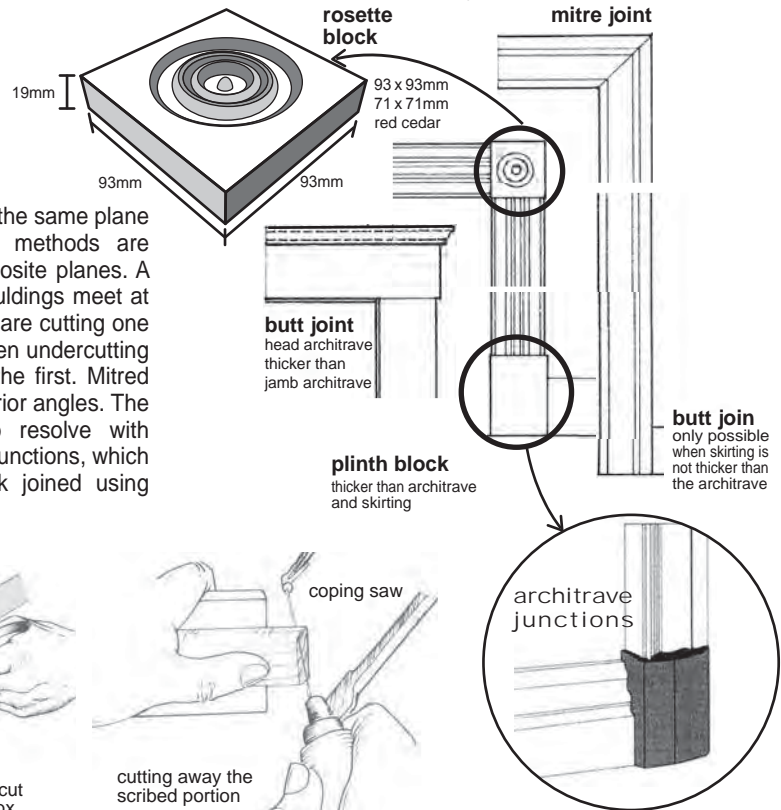
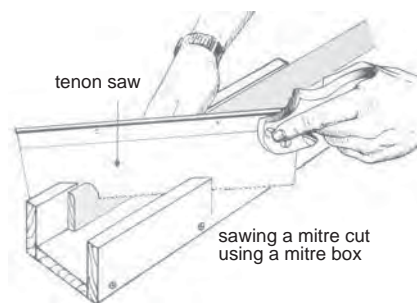

I LIKE THE CLASSIC LOOK OF ROSETTES & PLINTHS. WHAT OPTIONS ARE AVAILABLE?

Woodworkers can make plinths and rosettes to any size. Most commonly they are in red cedar to match other mouldings but other timbers can be quoted on request. Rosettes are carried in stock for standard 90mm architrave junctions with dimensions as per the detail. Plinths are usually run to order in longer lengths and docked to size on site to suit the application.

DO YOU SUPPLY MUSHROOM STOPS FOR DOUBLE DOOR APPLICATIONS?

Woodworkers has a range of mushroom stops sometimes called astragal moulds for situations where the look of a rebated door junction is not required. Mushroom stops can either be small unobtrusive sections or larger decorative items which can incorporate turned capitols and feet. We carry three designs for different purposes.

Small

used for maple doors generally as the section is so fine that it becomes fragile when manufactured in cedar.

Medium

used for cedar doors generally and is wider and thicker than the small mushroom but similar in shape.

Mediterranean stop

The largest of the mushroom moulds - normally is asymmetrical to increase its hold on the passive door. May be fitted with turned sections top and bottom to enhance its visual impact.

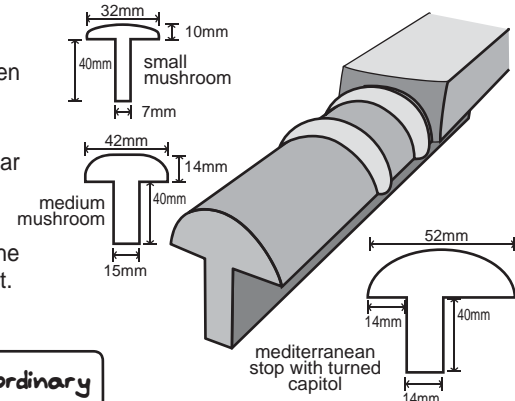

mouldings make the difference between ordinary & extraordinary

BRISBANE
1095 Ipswich Rd
Moorooka 4105
☎ 07 3848 1383
F: 07 3892 1476

GOLD COAST
Warehouse Road
Southport 4215
☎ 07 5571 0088
F: 07 5571 0617

SUNCOAST
53 Wisers Road
Maroochydore
☎ 07 5479 0999
F: 07 5479 0911

SYDNEY
2 Sydenham Rd
Brookvale 2100
☎ 02 9938 4999
F: 02 9938 4666